



Reactive Power Control of Transmission System using 48-Pulse GTO STATCOM

Pankaj Kumar Vishwakarma and Dr Arvind Kumar Sharma***

**Research Scholar, Department of Electrical Engineering,
Jabalpur Engineering College, Jabalpur, (Madhya Pradesh), INDIA*

***HOD Department of Electrical Engineering,
Jabalpur Engineering College, Jabalpur, (Madhya Pradesh), INDIA*

(Corresponding author: Pankaj Kumar Vishwakarma)

(Received 14 March 2017 Accepted 14 April, 2017)

(Published by Research Trend, Website: www.researchtrend.net)

ABSTRACT: In this paper we presented reactive power compensation in two FACTS devices both SATCOM and SSSC. Here we propose to tackle the existing problem in power transmission systems with multiple controller systems. The comprising a 48-pulse Gate Turn-Off thyristor voltage source converter for combined reactive power compensation and voltage stabilization of the electric grid network. This simulation of STATCOM and SSSC are developed in MATLAB/simulink environment by utilizing the blocks from the power system block set mean while control system is modeled. The proposed work is to decouple the both voltage and current control strategy with two controllers by SATACOM and SSSC. This problem is ensure that the system operates in stable condition with STATCOM with various loads and the phase locked loop inherent delay has a great effect on dynamic operation of SSSC and also is to regulate the proposed technique and to enhance the dynamic performance of SSSC this proposed 48 pulse control schemes are validated.

Key words: Static Synchronous, Compensator, Reactive Power Compensation.

I. INTRODUCTION

In the past, equipment used to control industrial process was mechanical in nature which was rather tolerant of voltage disturbances. Nowadays modern industrial equipment typically uses a large amount of electronic components such as program logic control (PLC) adjustable speed drives and optical devices which can be very sensitive to the voltage disturbances. The majority of disturbances that cause problems for electronic equipment's are voltage dip or voltage sag as in [1]-[2]. Voltage dips may cause tripping production disturbances and equipment damages. Voltage dips are huge problem for many industries and they have been found especially troublesome. Because they are random events lasting only a few cycles. However they are probably the most pressing power quality problem [3]. The concern for mitigation of voltage dip has been gradually increasing due to the huge usage of sensitive electronic equipment in modern industries. When heavy loads are started such as large induction motor drives, the starting current is typically 600% to 700% of the full load current drawn by the motor. This high current

cause dips in the voltage during starting intervals because there is a lot of voltage drop across the distribution conductor. Since the supply and the cabling of the installation are dimensioned for normal running current and the high initial current causes a voltage dip. This voltage dips are short duration reductions in rms input voltage as. It is specified in terms of duration and retained voltage usually expressed as the percentage of nominal rms voltage remaining at the lowest point during the dip. Another reason for high starting current is the inertia of the load as high starting torque and required to start the high inertia loads which can be obtained by using high starting current. This problem becomes more severe at peak loading time. This is due to the fact that at peak loading time the voltage of the system is less than the rated voltage. As the STATCOM is a solid-state voltage source converter coupled with a transformer tied to a line can injects reactive current or power to the system to compensate the voltage-dip. The Voltage-Source Converter (VSC) is the main building block of the STATCOM.

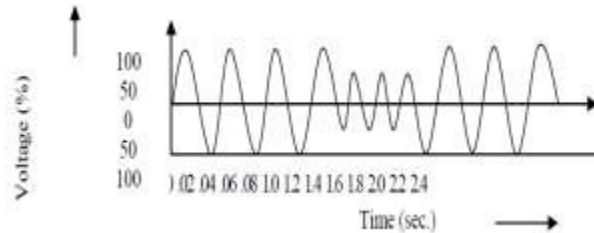

Fig. 1. Voltage Dip.

It produces square voltage waveforms as it switches the direct voltage source ON and OFF. The main objective of VSC is to produce a near sinusoidal AC voltage with minimum waveform distortion or excessive harmonic content. This can be achieved by employing multiple pulse converter configuration [4]. To obtain the multiple-pulse converters i.e. 12- pulse 24-pulse and 48-pulse VSC a two four or eight 6-pulse VSC can be used with the specified phase shift between all converters. A 48- pulse VSC can be used for high power applications with low distortion because it can ensure minimum power quality problems and reduced harmonic contents. A 48-pulse GTO based VSC can be constructed using two (24-pulse GTO based) converters shifted by 7.5° from each other. In this kind of converters there is no need of AC filters due to its low harmonic distortion content on the ac side. This new multiple-pulse converter configuration produces almost three phase sinusoidal voltage and maintains THD (Total Harmonic Distortion) well below 4% [5]. Srinivas K. V. *et al* [6] developed a three-level 24-pulse STATCOM with a constant dc link voltage and pulse width control at fundamental frequency switching validated the inductive and capacitive operations of the STATCOM with satisfactory performance. The harmonic content of the STATCOM current is found well below 5% as per IEEE standards. Sahoo A. K. *et al* [7] developed a simulation model of 48-pulse VSC based STATCOM FACTS devices. This full model is validated for voltage stabilization reactive power compensation and dynamic power flow control. It produces a sinusoidal AC voltage with minimal harmonic distortion from a DC voltage with variable loads. Huang S. P. *et al* [8] also investigated that the GTO based STATCOM consisting a 48-pulse three-level inverter regarding minimal harmonic distortion. It has fine dynamic response and can regulate transmission system voltage efficaciously. With the trend of progression of distributed generation within a bulk power system, there is a need to support bus bar voltage by injecting appropriate reactive power, which can also improve the dynamic behaviour of a power system. Static Synchronous Compensators

(STATCOMs) is a power electronic based synchronous voltage generator (SVG), which provides embedded control of transmission-line voltage and power flows. The paper represents the internal structure of the forty eight pulse STATCOM-based on two 24-pulse GTO-based converters, phase-shifted by 7.5° from each other for reduction in THD at the output voltage of the load in power systems. The integration of energy storage with a STATCOM can extend traditional STATCOM capabilities to four quadrant power flow control and transient stability improvement. The proposed model of the STATCOM is connected to a 25kv, 60 Hz system and simulation (in MATLAB) results are presented for demonstrating its steady state and dynamic performance. Fast Fourier Transform (FFT) analysis has also been carried out and the results showing the value of THD within acceptable limit and fast control of the reactive current. Thus the STATCOM shows excellent transient response to step change in the reactive current reference. With the trend of deregulating power industry and more distributed generators, the modern power system needs to provide stable, sufficient, secure, economic and high quality electric power to various load centers. This situation has spurred interest in providing already existing power system with greater operating flexibility and better utilization, thus having led to the concept of FACTS. The main purpose of introducing FACTS to the power system is to increase stability and transmission capability as stated by Hingorani & Gyugyi (2000). For transmission networks, one of the major consequence of the non discriminatory open access requirement is a substantial increase of power transfers, which demand adequate ATC, to ensure all economic transactions. Sufficient ATC should be generated to support free market trading and maintain an economical and secure operation over a wide range of system of condition as stated by Xiao *et al.* (2003). FACTS devices are also used for ATC enhancement, fast dynamic control of voltage, impedance, and phase angle in high voltage AC transmission system and they need a considerably smaller amount of real estate for their installation. The main drawback of using FACTS device is switching and conduction loss. Also voltage rating of switching devices is not enough. For high voltage application, we mostly use GTO (~ 6 KV rating max) as switching devices. To increase the voltage rating of power converter and so of the overall FACTS controllers, different multilevel topologies have been proposed by Lai and Peng (1996).

The hardware of a STATCOM is similar to the shunt branch of the Unified Power Flow Controller (UPFC) and can be controlled to provide concurrent real and reactive compensation with an external electric energy source adding to the DC bus as shown by Ma (2011). The series and shunt compensation has the purpose of handling reactive power to maintain bus voltage nearer to their nominal values, reduce line currents and system losses. By regulation of the STATCOM's output voltage magnitude, the reactive power exchanged between the STATCOM and the transmission system can be controlled, as expressed by Hingorani & Gyugyi (2000). The circulating power in the grid that does no useful work which results from energy storage elements in the power grid has a strong effect on the system voltage collapse and current distortion is mainly generated by non linear loads (electronic load). This current distortion affects the power system stability and distribution equipment. By adjusting terminal voltage of generators and tap changing of OLTC, particularly rescheduling generator outputs are considered as major control measures for ATC boosting. This paper presents the design of eighty-four-pulse VSC based STATCOM for satisfactory performance in performing various reactive power flow control function during steady-state and transient operations of power systems. Sood (2004) expresses how multi-purpose circuit configurations are employed to reduce the harmonic generation and to produce practically sinusoidal current.

II. WORKING PRINCIPLE OF STATCOM

The essential component in a VSC based STATCOM are GTO-VSC bridge (s), DC capacitor (c), working as an energy storage device, interfacing magnetic forming the electrical coupling between the VSC bridge circuit, AC mains system and controller generating gating signals, as presented by Singh and Saha (2006). The reactive power exchange between the AC system and the compensator is controlled by varying the fundamental component magnitude of the inverter voltage, above and below the AC system level. The compensator control is achieved by small variations in the semiconductor devices switching angle, so that fundamental component of the voltage generated by the inverter is forced to lag or lead the AC system voltage by a few degrees causing the flow of active power into or out of the VSI & the resultant reactive power. The schematic configuration and power exchange of STATCOM. The controlled output voltage is maintained in phase with the line voltage, and can be controlled to draw either capacitive or inductive current from the line rapidly. STATCOM has the ability to maintain full capacitive output current at low system

voltage, which improves the transient stability output voltage of VSC bridge (E_s) is governed by dc capacitor voltage which is controlled by varying the phase difference between (E_s) and (E_t) (system voltage at bus). The magnitude and phase difference of I_q determine the magnitude and phase difference between E_s and E_t across the transformer leakage inductance, which, in turn, controls reactive power flow. The basic objective of a good VSI-converter scheme is to produce a near sinusoidal ac voltage with minimal wave form distortion or excessive harmonics content. Three basic techniques can be used for reducing the harmonics produced by the converter switching. Harmonic neutralization using magnetic coupling (multi pulse converter configurations), harmonic reduction using multilevel converter configurations, and novel pulse-width modulation (PWM) switching techniques. The 24- and 48-pulse converters are obtained by combining two or four (12-pulse) VSI, respectively, with the specified phase shift between all converters. For high-power applications with low distortion, the best option is the 48-pulse converter, although using parallel filters tuned to the 23th–25th harmonics with a 24-pulse converter could also be adequately attentive in most applications, but the 48-pulse converter scheme can ensure minimum power quality problems and reduced harmonic resonance conditions on the interconnected grid network.

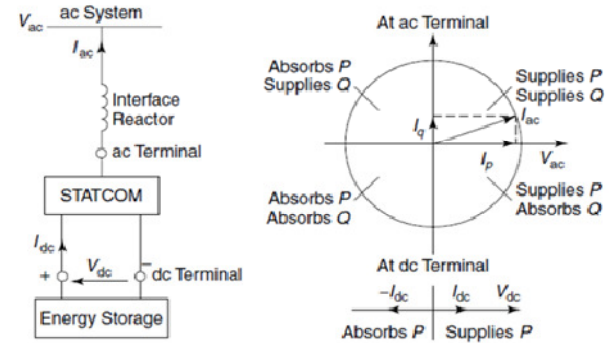

Fig. 2. Equivalent circuit of STATCOM.

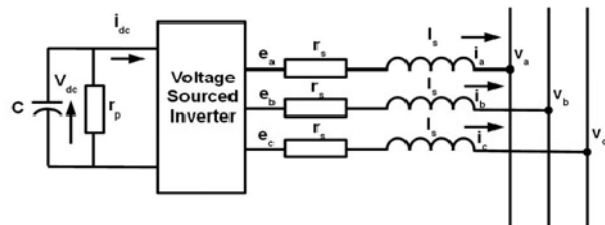

Fig. 3. Basic representation of the six-pulses STATCOM.

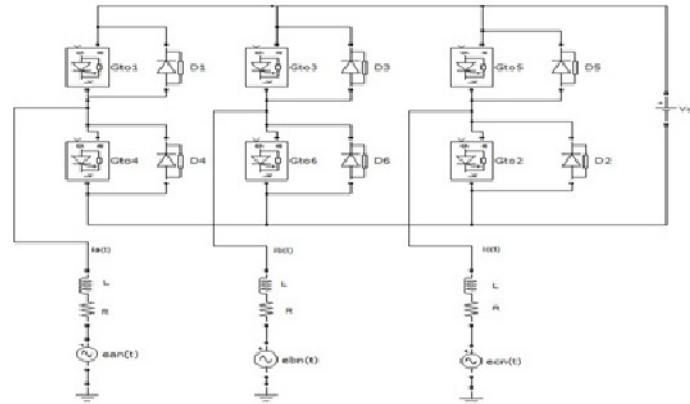

Fig. 4.

III. CONTROL OF STATCOM

We can control the output voltage of STATCOM by the following two methods.

1. Indirect control: By controlling the dc capacitor voltage, reactive output current can be controlled.

2. Direct control: When dc voltage is kept constant, this type of control can be obtained by internal voltage mechanism of the multilevel VSI. In case of indirect vector control method, three phase currents are transformed to direct and quadrature axis, which are then synchronized with the ac system (3 phase) voltage via a phase locked loop (PLL). The d-axis and q-axis voltages generated by vector control are then transformed to three phase quantities and converted into line voltages by multilevel VSI. By increasing or decreasing the capacitor voltage by using control system block, we can obtain the correct amplitude of VSI output voltage for the required reactive power. A frequently used measure of harmonic level of VSI output voltage is total distortion (THD) or distortion factor (DF). THD is the ratio of RMS value of the harmonics (except fundamental) to the RMS value of the fundamental, times 100%. The power system is an interconnection of generating units to load centres through high voltage electric transmission lines and in general is mechanically controlled. It can be divided into three subsystems: generation, transmission and distribution subsystems. In order to provide cheaper electricity the deregulation of power system, which will produce separate generation, transmission and distribution companies, is already being performed. At the same time electric power demand continues to grow and also building of the new generating units and transmission circuits is becoming more difficult because of economic and environmental reasons. Therefore, power utilities are forced to rely on

utilization of existing generating units and to load existing transmission lines close to their thermal limits. However, stability has to be maintained at all times. Hence, in order to operate power system effectively, without reduction in the system security and quality of supply, even in the case of contingency conditions such as loss of transmission lines and/or generating units, which occur frequently, and will most probably occur at a higher frequency under deregulation, a new control strategies need to be implemented. The future growth of power systems will rely more on increasing capability of already existing transmission systems, rather than on building new transmission lines and power stations, for economical and environmental reasons. Ideally, these new controllers should be able to control voltage levels and flow of active and reactive power on transmission lines to allow for their secure loading, to full thermal capability in some cases, with no reduction of system stability and security. The location of STATCOM for power flow control in transmission system has been presented [1]. The FACTS devices are introduced in the power system transmission for the reduction of the transmission line losses and also to increase the transfer capability. STATCOM is VSC based controller to regulate the voltage by varying the reactive power in a long transmission line. The effectiveness of SVC and STATCOM of same rating for the enhancement of power flow has been demonstrated [2]. The modeling of converter-based controllers when two or more VSCs are coupled to a dc link has been presented [3]. The optimal location of shunt FACTS devices in transmission line for highest possible benefit under normal condition and has been investigated [4]. A shunt connected controllable source of reactive power, and two series connected voltage-sourced converters - one on each side of the shunt device was presented [5].

An overview of how series connected and combined series/shunt connected FACTS controllers are studied in an AC system has been highlighted [6]. The optimum required rating of series and shunt flexible ac transmission systems controllers for EHVAC long transmission lines by computing 'optimum compensation requirement' (OCR) for different loading conditions has been demonstrated [7]. A series passive compensation and shunt active compensation provided by a static synchronous compensator (STATCOM) connected at the electrical centre of the transmission line to minimize the effects of SSR has been presented [8]. A novel approach for damping inter-area oscillations in a large power network using multiple STATCOMs was given [9]. The effective utilization of FACTS device called unified power flow controller (UPFC) for power flow control was presented.

V. CONCLUSION

STATCOM and SVC are connected at the various locations such as sending end, middle and receiving end of the transmission line. Based on a voltage source converter, the statcom regulates system voltage by absorbing or generating reactive power. The results are obtained with and without compensation using matlab/simulink environment. The simulation results reveal that the reactive power obtained for STATCOM is better when compared with SVC at the middle of the transmission line. So, the location of STATCOM is optimum when connected at the middle of the long transmission line. The numerical results of the system analysis

REFERENCES

- [1]. N. G. Hingorani and L. Gyugyi, "Understanding FACTS: Concepts and Technology of Flexible AC Transmission System," New York, NY: IEEE press, 2000.
- [2]. V. K. Sood, "Static Synchronous Series Compensator Model in EMTP," *ICCC Canadian Conference on Electrical and Computer Engineering*, Vol. 1, No.3, pp. 207-211, Winnipeg, May 2002.
- [3]. S. Salem and V.K. Sood, "Modeling of Series Voltage Source Converter applications with EMTP-RV," *International Conference on Power System Transient (IPST'05), Montreal*, June 19-23, 2005.
- [4]. L. Gyugyi, K. K. Sen, and C. D. Schauder, "The Interline Power Flow Controller Concept: A New Approach to Power Flow Management in Transmission Systems," *IEEE Transactions on Power Delivery*, Vol. 14, No. 3, July 1999.
- [5]. S. Teerathana, A. Yokoyama, Y. Nakachi, and M. Yasumatsu, "An Optimal Power Flow Control Method of Power System by Interline Power Flow Controller (IPFC)," in *Proc. 71st International Power Engineering Conference, Singapore*, pp. 1-6, 2005.
- [6]. X. P. Zhang, "Modeling of Interline Power Flow Controller and The Generalized Unified Power Flow Controller in Newton Power Flow ", *Proc. Institution Electrical Engineering, Generation, Transmission, Distribution*, Vol. 150, No. 3, pp. 268-274, May 2003.
- [7]. Jianhong Chen, T.T. Lie, and D.M. Vilathgamuwa, "Basic Control of Interline Power Flow Controller," *IEEE Power Engineering society winter meeting*, vol. 1, pp. 521-525, January 2002.
- [8]. Ali Ajami and Abdel-rahim Kami, "Modeling and Controlling of Interline Power Flow Controller Based Current-Source Converter," *Second International Conference on Computer and Electrical Engineering 2009*, Vol. 1, pp. 353-357. January 2010.
- [9]. S. R. Aali and D. Nazarpour, "48-Pulse GTO Interline Unified Power Flow Controller," *First Conference on Power Electronic & Drive Systems & Technologies*, pp. 52-56. February 2010.
- [10]. H. Fujita, Y. Watanabe and H. Akagi, "Dynamic Control and Performance of a Unified Power Flow Controller for Stabilizing an AC Transmission System," *IEEE Trans. Power Elect*, Vol. 21, no. 4, pp.1013-1020, July, 2006.
- [11]. B. Kawkabani, Y. Pannatier and J. J. Simond, "Modeling and Transient Simulation of Unified Power Flow Controllers (UPFC) in Power System Studies," *2007 IEEE Lausanne Power Tech*, pp. 333-338, Lausanne, July 2007.
- [12]. S. Tara Kalyani and G. Tulasiram Das, "Control and Performance of UPFC Connected to a Transmission Line," *2007 International Power Engineering Conference (IPEC 2007), Singapore*, 2007, Vol. 2, no. 6, pp. 302-307, Dec 2007.