



## Study of use of Bio-degradable Alternative fuels for Transport and Energy sector in India

*Atam Parkash Papreja\* and S.K. Mahla\*\**

*\*Research Scholar, Shri Venkateshwara University, Gajraula, (UP), INDIA*

*\*\*Director-Principal, Adesh Institute of Engineering Technology, Faridkot, (PB), INDIA*

*(Corresponding author: Atam Parkash Papreja)*

*(Received 04 October, 2015 Accepted 04 November, 2015)*

*(Published by Research Trend, Website: [www.researchtrend.net](http://www.researchtrend.net))*

**ABSTRACT:** Depleting fossil fuel resources, mounting outflow of foreign currency, stringent emission control legislation and global warming have necessitated serious thinking in the Government of India and automobile manufactures to look for alternative eco-friendly, non-toxic and renewable fuels. Out of various alternatives emerged from the exhaustive research carried out by renowned researches, biofuels gained acceptance both commercially and technically and are being used by various countries.

### I. INTRODUCTION

India is of late fast progressing and in the transition phase from developing country into developed country and even there is talk of becoming of its Superpower. This has been corroborated by the least impact of Chinese's devaluation of currency on Indian economy and this is so because of strong fundamentals of macro and micro economy and a large and strong consumer base. Most of the US business conglomerates are now saying that India is the growth engine for Asia. But this could be possible only if we are able to overcome the severe energy imbalance and constraints and more so to achieve a sustained growth in manufacturing under the ambitious "Make in India" plan

And cherished dream of our Honorable Prime Minister of India to take the country towards economic growth which is the only tool for eradicating poverty and unemployment.

As we all know that energy, a key fundamental part of our Universe, has become a strategic commodity and its uncertain supply can threaten the functioning of the entire economy and dither our hopes of becoming developed economy. Therefore it is imperative that serious concerted efforts will have to be made the Government in this regards.

### II. ENERGY CONSUMPTION OF INDIA

Due to rapid development of Indian economy, it has become one of the world's fastest growing energy markets and is expected to be the second largest

contributor to the increase in global energy demand by 2035, accounting for 18% of the rise in global energy consumption [2]. As on date, it is the fourth largest consumer of energy after China, USA and Russia. The total primary energy consumption of India in the year 2013 was as follows:

-29.4% from crude oil

-7.7% from natural gas

-54.5% from coal

-1.26% from nuclear energy

-5.0% from hydro

-595 Mtoe of wind power, biomass and solar power

As is evident from above, 70% of requirement of energy is met from imported fossil fuels and by 2030; India's dependence on fossil fuels is expected to increase 53% of country's total energy requirement [2].

### III. NEED OF ALTERNATIVE FUEL

Given India's growing energy demands and thus increasing import bills with diminishing stock of fossil petroleum fuels, global warming, pollution and introduction of stringent emission legislation, scientists and the governments throughout the world have been engaged in finding and developing alternate biodegradable fuels. Since fossil fuels are still going to play a crucial role in our fast growing economy and because of its depleting resources, they need to be used prudently. The scientists from all the over the world have unanimously agreed that the average temperature of the earth is increasing and human activity is one of the principal causes as is evident from the global warming.

Global climate change and increasing stringent emission regulations have become the motivational factor for the development and commercialization of renewal energy. In today's world with growing concerns over energy crisis, biodegradable renewable energy is considered to be the best alternative and has the ability to propel a nation to a new level of prosperity. Among the various types of renewable energy, bio fuels stands at the forefront as a substitute to petroleum fuels.

Mother Nature has always been kind to human being and had even been looking after its energy needs, from the inception of universe, in a renewable manner. The industrial revolution in the nineteenth and twentieth century had thrown opened the opportunities to exploit the earth's fossil reserves i.e. fossil oil, coal and natural gas. Though these energy reserves looked to be unlimited in the beginning but the latest surveys expressed concerns not only in terms of its abundant availability but grave concerns of its harmful emission. The miracle of nuclear energy and its bitter experiences of leakages of radiations and its after effects has compelled us to be more cautious in its use as a clean energy source. Therefore the current circumstances have brought back renewable energy again into limelight.

#### IV. ALTERNATIVE FUELS

Since the major consumer of fossil fuel are railways, transport and agricultural sector, the government of India through Central Pollution Control Board (CPCB) commissioned a study in 90s and mid 90s to assess the feasibility of various alternatives and various organizations viz. Indian oil Corporation (R&D), Society for Indian Automobiles Manufacturers (SIAM), Ashok Leyland, Tata Engineering, Scooters India Ltd., Bajaj Auto Ltd., Mahindra & Mahindra and other manufacturers have been carrying out field trials with alternate fuelled vehicles. Moreover with the advancement of engineering excellence throughout the world, the idea of reverting back to the ages of the bull carts has compelled everyone to search for alternative fuels.

It is not only the development of alternatives fuels to petroleum-based fossil fuels that is important but equally important is its sustainability commercially which is possible provided they meet the following criteria:

- Technical acceptability
- Economically competitive
- Environmentally acceptable
- Transportation
- Safety & availability

Keeping in view the above criteria, of all the alternative fuels developed, the bio fuels which are eco-friendly, biodegradable and renewable bio-mass based fuels have proved to be the most acceptable alternative fuel which can be used directly or in blending with diesel fuel without any alternation in the existing compression ignition engines being used largely in transport sector which is a growth engine for the Indian economy as well as meeting the energy needs of India's vast rural population.

#### V. BIO FUEL

Bio fuels are broadly classified as: Biodiesel and Alcohol

The continuous research in development of alternate fuel throughout the world, has lead to the concept of bio fuel, oxygenated by nature [6], which is a liquid fuel produced from crops and plants and the crops that are used for the production of bio fuel are called energy crops and can be either biodiesel or ethanol. Since they are produced from plants and crops which are cultivated has thus become source of hope for the farmers, many of whom live in poverty. The additional fact that that bio fuel production does not require high technology has brought cheers in the lives of poor farmers and agricultural industry.

##### A. Biodiesel

One hundred years ago, Dr. Rudolf Diesel tested pea nut vegetable oil as fuel for the first time on August 10, 1893[5]. Vegetable oils, both edible and non-edible oils though hold special promise in this regard and excellent ignition characteristics, have failed to find wide acceptability in the market due to higher viscosity, gum formation, problem of carbon deposits and poor thermal efficiency [7]. However it still possesses enormous potential and its performance can be greatly improved by transesterification process which is nothing but modification/converting of vegetable oil into biodiesel, also known as fatty acid alkyl ester by chemically reacting with methanol/ethanol in the presence of catalyst such as NaOH thereby making it the most sought after alternative to be used as a substitute for petro diesel in diesel engines. The following reaction demonstrates the reaction process:

The product so formed is known as Biodiesel which is gaining popularity because of its being biodegradable, non toxic and eco friendly fuel and its advantages over diesel fuel which includes high cetane value, low smoke and particulates, low carbon dioxides and hydrocarbon emissions. The Government of India has in its policy on biofuels has emphasized the use of non-edible oils for production of biodiesel because of vegetable oils being used as cooking oil by masses in Indi

### B. Oil yields of common oil crops

Oil yields of different edible and non edible oil producing crops which are being used for production of biodiesel are given in table no.

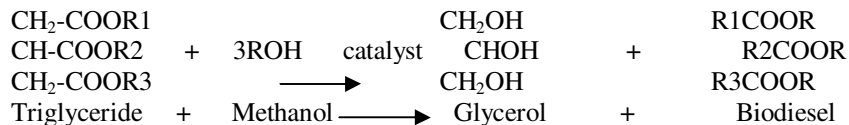

**Table 1: Oil yields of common oil crops.**

Serial Number	Crop	Yield in kgoil/hectare
1	Corn( Maize)	145
2	Soybean	375
3	Linseed	402
4	Sunflower	800
5	Rapeseed	1000
6	Castor beans	1188
7	Jojoba	1528
8	Jatropha	1590
9	Coconut	2260

Source: Journeytoforever.com

### C. Alcohol

The Clean Air Amendments of 1990 mandated the sale of oxygenated fuels in areas with unhealthy levels of carbon monoxide. Since then, blending of ethanol with gasoline to form E10 blend (10% ethanol and 90% gasoline) is being used. Even its use as blend in higher concentrations is also being contemplated.

## VI. POLICY OF GOVERNMENT OF INDIA TOWARDS DEVELOPMENT AND USE OF BIO FUELS

Government of India in its National Policy on Biofuels envisioned a central role in accelerated development and promotion of the cultivation, production and use of biofuels in energy and transport sector to increasingly substitute petrol and diesel thereby contributing to climate control apart from creating new employment and reducing burden of import bill on the National exchequer. It was decided that to start with an indicative target of 20% blending of biofuels, both bio-diesel and bio-ethanol, by 2017 has been proposed

## VII. RESULTS AND DISCUSSION

The scholar is pursuing PhD in biofuels and while studying and reviewing technical literature and research papers, it has been observed that most of the work has been done in experimental investigation of performance analysis and emission characteristics of either blends of biodiesel, prepared from various edible and non-edible oils, with diesel or ethanol with diesel. Very little work has been carried out in ternary blend of biodiesel, alcohol and diesel. The scholar is undertaking study of performance analysis and emission characteristics of ternary blend of castor biodiesel, n-butanol and diesel with the following objectives:

- (i) Performance analysis and evaluation of engine exhaust emissions of castor biodiesel-diesel fuel blend in various proportions and finding out the optimum blend for achieving desired results.
- (ii) Performance analysis and evaluation of engine exhaust emissions of n-butanol-diesel fuel blend in various proportions and finding out the optimum blend for achieving desired results.
- (iii) Comparative analysis and evaluation of engine exhaust emissions of ternary blend of castor biodiesel-n-butanol-diesel fuel blend in various proportions and finding out the optimum blend for achieving desired results.

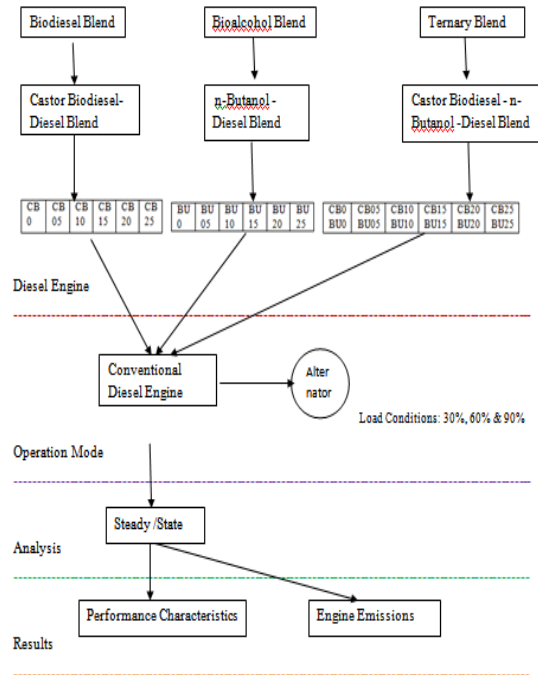

Fig. 1.

REFERENCES

[1]. Energy Statistic, 2015, "Central Statistics office, National Statistical Organization, Ministry of statistics and programme implementation, Government of India".  
 [2]. <https://en.wikipedia.org/wiki/Energy-Policy-of-India>.  
 [3]. Parivesh, A News Letter from ENVIS Centre-Central Pollution Control Board, <http://www.cpcbenvnis.nic.in/newsletter/alternatefuel/content0403.htm>[9/6/2012 10:43:38 AM]  
 [4]. National Policy on Bio fuels, Government of India.

[5]. Deshpande D. P., Urunkar Y.D. and Thakare P.D. "Production of Biodiesel using acid and base catalysts." *Research Journal of Chemical Sciences*, Vol. 2(8), 51-56. August (2012).  
 [6]. D. C. Rakopoulos, C.D. Rakopoulos, D.T. Hountalas, E.C. Kakaras, E.G. Giakoumis and R.G. Papagiannakis. "Investigation of the performance and emissions of bus engine operating on butanol/diesel fuel blends" Elsevier. *Fuel* 89 (2010) 2781-2790.  
 [7]. S.S. Ingle and V.M. Nandedkar "Castor oil Biodiesel an alternative fuel for Diesel in Compression Ignition Engine" *IOSR Journal of Mechanical and Civil Engineering*, ISSN(p): 2320-334X, PP: 10-13.