



Design of Smart Pulse Oximeter using ATMEGA 328 Microcontroller

Deivasigamani S.¹, G. Narmadha², Manickam Ramasamy³, Haarindra Prasad¹ and Pratap Nair¹

¹Faculty of Engineering and Computer Technology, AIMST University, Malaysia.

²Department of Electrical and Electronics Engineering, Sethu Institute of Technology, TamilNadu, India.

³Department of Electrical & Electronic Engineering, UCSI University, Malaysia.

(Corresponding author: Deivasigamani S.)

(Received 23 March 2020, Revised 04 May 2020, Accepted 05 May 2020)

(Published by Research Trend, Website: www.researchtrend.net)

ABSTRACT: Blood oxygen level (SpO₂) is an estimating of the measure of oxygen conveyed in the haemoglobin. SpO₂ for a sound individual adrift level ought to be at or above 94%, while the patients with the constant pulmonary infection will attempt to keep up their SpO₂ above 90% by utilizing valuable oxygen. Subsequently, an ease and convenient heartbeat oximeter are utilized to acquire the oxygen immersion level. However, present device is powered by batteries which have a shorter lifespan and also the main challenge of pulse oximeter is that the lack of generalisability. Hence, a solar-powered pulse oximeter is proposed in this research work to implement solar energy on the device to increase the lifespan of the device, eco-friendly and cost-effective. Furthermore, the device is interfacing with the Internet of Thing (IOT) technology which for monitoring and remote alert purposes. With the IOT system, the blood oxygen level of the patients can be updated to the monitoring device in real time. Hence, the doctor can keep tracking and monitoring the condition of the patients. A Solar Powered Pulse Oximeter with Remote Monitoring Network was designed with Max30102 model by using the Eagle software.

Keywords: Arduino uno; IoT; Solar power; Pulse oximeter sensor; SpO₂.

I. INTRODUCTION

Nowadays, the risk of health is increasing and threatening the millions of lives. There is a dynamic increment in cardiovascular ailments bringing about around 8 million passing's yearly overall which can be ascribed to hypertension. Moreover, 142 per 1000 live births with acute respiratory infections being one of the leading causes of deaths. An ordinary sound individual ought to have the option to accomplish typical SpO₂ of 94% to 99%. For patients with mellow respiratory ailments, the SpO₂ ought to be 90% or above. Beneficial oxygen ought to be utilized if the SpO₂ level falls beneath 90%, which is unsatisfactory for a drawn out timeframe and is appeared in the Fig. 1. Along these lines, the beat oximeter is especially lacking in low-pay nations, where the inaccessibility of a dependable, tough, and reasonable estimation gadget is a significant impediment to precise diagnosis in single gadgets. Besides, the device powered with a solar panel and attached rechargeable battery to overcome the problem of sudden power cut and can be used anywhere. In previous years, the circuit consists of a microcontroller (PIC18F452), transistor network, PPG (photoplethysmogram amplifier), digital-to-analog converter (DAC), pulse oximeter probe and an LCD screen to display results. Coding has been written in C++ and also supports only limited C syntax. This is the major drawback of the already existing system and it has been overcome with the proposed system which has been implemented by using IoT.

Pulse oximetry is a non-obtrusive and easy test that gauges your oxygen immersion level or the oxygen levels in your blood. It can quickly distinguish even little changes in how effectively oxygen is being conveyed to the limits uttermost from the heart, including the legs and the arms. The oximeter is a little, cut like gadget that appends to a body part, similar to toes or an ear cartilage. Its most usually put on a finger, and it's regularly utilized in a basic consideration setting like crisis rooms or medical clinics. During a pulse oximetry

perusing, a little cinch like gadget is set on a finger, ear cartilage, or toe. Little light emissions go through the blood in the finger, estimating the measure of oxygen. It does this by estimating changes of light assimilation in oxygenated or deoxygenated blood. This is a painless process.

The reason for pulse oximetry is to check how well your heart is siphoning oxygen through your body. It might be utilized to screen the strength of people with a condition that can influence blood oxygen levels, particularly while they're in the medical clinic. These conditions incorporate constant obstructive pulmonary disease (COPD), asthma, pneumonia, lung disease, pallor, cardiovascular failure or cardiovascular breakdown and inherent heart deserts. The Internet of Thing alludes to the association of gadgets, for example, PC and cell phones to the Internet. It comprises of all web-empowered gadget that gathers, sends and follows up on the information they gain from their general surroundings utilizing implanted sensor, processors and correspondence equipment. People can interact with the gadget to set them up, give them instruction or access the data. Hence, people can access the device anywhere and keep the data updated in real time. The gadget can help to monitor for the changing conditions of patients anytime. For this project, the IOT device implemented was the Bluetooth module HC-06 which is able to sync with Arduino Uno and is displayed on the computer using Tera Term.

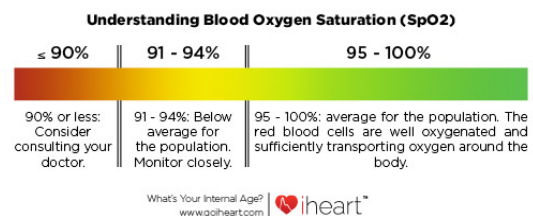

Fig. 1. Levels of SpO₂.

II. LITERATURE REVIEW

Armand and Tarascon (2008) expressed that Lithium-particle batteries have been the decision of battery science for fueling customer hardware because of their high vitality, high force thickness, stable electrochemical execution and the capacity to be energized [1].

Charging would turn out to be increasingly helpful if the battery is joined with at least one gadgets that gather vitality from encompassing sources, for example, light, warm, or vibrational vitality [2,3]. Of the different vitality collecting strategies, photovoltaics (PV) are frequently the most appropriate for charging high-limit batteries on account of the generally high accessible force lair-sity on the request for $100\text{mW}/\text{cm}^2$ outside or several $\mu\text{W}/\text{cm}^2$ inside, contrasted with tens to hundreds of $\mu\text{W}/\text{cm}^2$ for warm and vibrational sources. Ostfeld *et al.*, (2016) built up a sun based fueled pulse oximeter. The existing authors planned a wearable social insurance gadget which included adaptable lithium-particle batteries, photovoltaic vitality collecting module and heartbeat oximeter segments. The lithium-particle batteries are accused of the photovoltaic module to keep up the force gracefully for the wear-capable wellbeing checking gadget. The battery was steady all through charging and releasing at rates up to 3C under the rehashed charge and release cycling and flexing. The charging of the battery from the PV module with irradiance running from 0.9 to 100 for indoor and outside enlightenment condition [4].

Honna (2012) proposed a remote patient checking framework which is utilized for constant observing of two wellbeing parameters, for example, oxygen immersion and temperature of body [5]. The author has effectively actualized remote patient observing framework by utilizing the MSP430FG437 processor, pulse oximeter, LM35 sensor and ZigBee trans-recipient module. The author used the low power consumption processor and wireless technology to enable long-lasting battery life. The author achieved a high precision value of 95% to 99% and the measured parameters are displayed on the VB application. Mahgoub *et al.*, (2015) presented a remote pulse oximetry system for health monitoring by collecting the data of a patient then send an SMS message to a mobile device. The authors had successfully developed an oximeter circuit based on transmittance mode and reflectance mode. An infrared sensor was attached to filter the noise to gain a better signal. At the point when the oxygen immersion is beneath 95%, the program will start the GSM shield to send a SMS message to the cell phone as a ready notice [6]. Gavhale *et al.*, (2017) presented a low-power pulse oximeter by using Arduino UNO which is wearable and suitable for use in emerging portable. The authors used an amplifier unit to compare blood particles and oxygen and give the voltage difference in the amplified form whereas finger probe and pressure sensor were used to measure the oxygen saturation and blood pressure. The information of oxygen saturation and heart rate is shown on the LCD display [7].

Azizulkarim *et al.*, (2017) presented a patient monitoring system which is used to monitor the pulse rate of the patients [8]. It is a portable patient monitoring device that consists of a pulse sensor and temperature sensor which are used to measure the pulse rate and temperature reading through the fingertip and it is interfaced to PC via Arduino microcontroller. There are 3 conditions: cold, normal and hot were tested for the body temperature whereas the pulse sensor was tested on

two occasions, after running and at rest. The collected data are sent to the health provider's medical personnel via email. Patil and Umale (2015) presented the design and implement wireless biomedical parameter monitoring system based on blood pressure & pulse rate sensor, ECG-3 Lead Module and temperature sensor using Arduino Uno with Zigbee module as wireless transmitter and receiver [9]. The measured readings of different parameters are displayed on the LCD display using the microcontroller and the data were transmitted wirelessly to the doctor to monitor the overall health condition of the patients. Longmore *et al.*, (2019) presented a method to measure SPO₂, heart rate and respiration rate but the proposed system was powered by solar cell and it can be used for remote monitoring [12].

Sarvaiya *et al.*, (2019) is stated Heart Related disease usually occurs in women after menopause and in men above the age of 40, and most people who die of heart attacks are above the age of 65 and authors discussed about the various types of heart diseases problem with data mining technique without oxygen saturation level of patients [13].

III. PROBLEM DESCRIPTION

People with low blood oxygen levels are often clueless about their condition. Majority of the patients don't have the time and resources to visit the doctor for medical check-ups. Going to the hospital for these check-ups are a hassle for older patients who are wheelchair bounded or immobile. The normal individual that utilizes a pulse oximeter is evaluated to associate with fifty years old [10]. Therefore, the Solar Powered Pulse Oximeter Monitoring is proposed in this research work to assist in measuring the oxygen saturation level of patients remotely.

This proposed system enables the patient to detect their blood oxygen levels at home to ensure the heart rate is normal at different condition. Genuine respiratory disappointment happens when blood vessel immersion of hemoglobin falls beneath 90%, this rate generally extends between 85-90% [11]. In this way, beat oximeters permit their patients to inhale simpler by estimating the oxygen immersion of blood vessel blood in their bodies. In addition, the proposed system runs on a non-conventional source of energy which is eco-friendly and cost-effective. This system will overcome the limits of the existing system as there is a certain level of innovation put into it.

IV. PROPOSED METHODOLOGY

A. Block Diagram

The system of the proposed solar-powered pulse oximeter monitoring with the remote alert is depicted in Fig. 2. The proposed framework comprises of a solar panel, a pulse oximeter sensor, a microcontroller (AtMega328), a LCD display and Tera Term display on PC.

The solar power energy is used as the power supply to the device. Since, the power source is renewable energy, the source of power is infinite. A solar panel is applied to the device to capture the energy from the sunlight. When the sunlight is captured by the solar panel, it will convert the solar energy into electrical energy and it is supplied to the device. A battery bank is implemented on the device as a power storage bank or as a backup source of energy for emergency use.

A pulse oximeter sensor is utilized to quantify oxygen immersion from the transmitted and got frequencies of

the light. The sensor test contains the Light Emitting Diode and a photodiode to get the light originating from the finger. The pulse oximeter probe includes one visible red spectrum (660nm) and an infrared spectrum (940nm). The emitter and the photodiode are inverse of one another with the estimating site in the middle. The light skips from emitter to the detector over the site. The blood vessel blood volume over the estimating site increments immediately when there are a flood of blood vessel blood and heartbeat the heart contracts. Hence, more light absorption happens. A comparator amplifier is used to form the reading detectable and to convert the current into voltage.

The microcontroller is connected to the pulse oximeter sensor, to process the signal from the sensor and then the data is shown on the display and sent to the monitoring device via IOT (HC-05 Bluetooth Module). The Arduino IDE will be used to program the code into the microcontroller to carry out the data processing, data display and remotely control. The proposed system in this proposal will be an eco-friendly device and it is more convenient for the patient and the doctor to keep monitoring the patient's condition from time to time.

LCD display is where the reading of the pulse oximeter is shown. The programmed microcontroller will initiate the pulse oximeter sensor and interface with the LCD display. When the finger tip is placed on the top of the pulse oximeter, the oxygen level is measured through the transmitting and receiving wavelength of the light. The measurement result is shown on the LCD as well as Tera Term through bluetooth connection. The readings displayed on Tera Term can be saved in a log form by users and can easily be sent to the doctor for monitoring purpose.

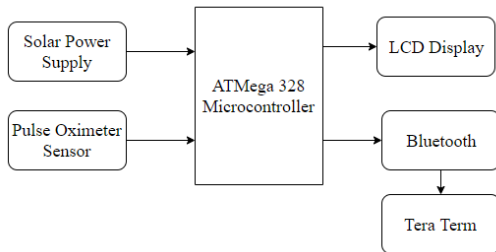

Fig. 2. Block Diagram of the System.

B. Flow Chart

The flowchart of the proposed solar-powered pulse oximeter monitoring with the remote alert is shown in Fig. 3. As the previous block diagram explanation the device consists of a solar panel, a pulse oximeter sensor, a microcontroller (AtMega328), a bluetooth unit and a LCD demonstration.

Meanwhile, the solar power energy is used as the power supply to the device. The solar panel will be initiates the pulse oximeter sensor. When the oximeter is initiates the red LED will emit. Then, it is shown as the pulse oximeter is ready to use. So, the pulse oximeter can be placed usually on a fingertip or ear lobe. The placement of the pulse oximeter on the body part is according to the design of the device.

When the pulse oximeter is not attached to the body part, it is not initiates. Moreover, the data is not complete or remove sensor from body attachment.

The process will be start from the beginning due to collect data complete. Meanwhile the sensor is attached to body part. As the sensor is reflective type, so there will be some fixed light reflection back to the sensor from the body part. After the some of the infrared light absorbs by oxygenated blood and the de-oxygenated blood absorbs more red light. The signal will be transmitted to the microcontroller. As the program, the amount of absorbs of infrared and red light in the blood is compared. Then, it will calculate the amount of oxygen ratio in the blood.

After the data was collected, the data will be display on the LCD. Patient can be read the data immediately and response to the result. If the condition is critical, the patient has to consult doctor or has to contact to hospital immediately. Furthermore, the patient can be monitoring their oxygen level in the blood frequently at home if they feel any of the symptoms that they are lacking oxygen in blood.

Besides that, for more information, the patient can connect the device to PC by connecting the Tera Term through Bluetooth module. The more details reading is shown on the terminal which keep looping the reading from the sensor. From the reading shown on the terminal, the patient can see their blood oxygen saturation level on the monitor and the patient can keep the reading as a record.

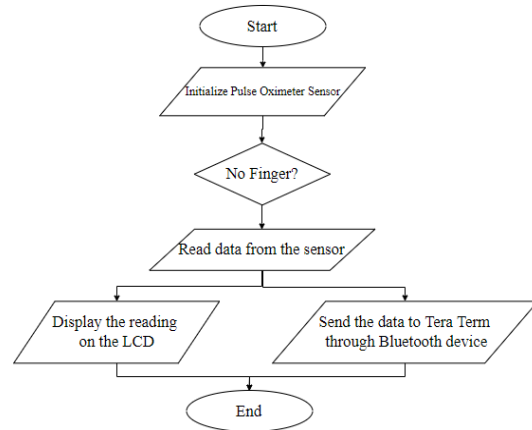

Fig. 3. Flow Chart of the System.

C. Algorithm

Algorithm of the device is shown in Fig. 4. The device is a solar powered device, which the solar energy can be captured by the solar panel and deposited in the 3.7V rechargeable lithium ion battery in order to power up the pulse oximeter device. When the battery is drained, we expose the device to the sunlight to recharge the battery. After charging the battery, a DC-DC converter and booster is used to boost the power supply from 3.7V to 5V.

After powering up the device, we can place our fingertip on top of the pulse oximeter to measure our blood oxygen immersion level. The blood oxygen fullness level is the ratio of red value and IR value which measured through the transmitting and receiving wavelength of the light. The IR value and the blood oxygen saturation level is shown on the LCD for monitoring purpose. We can also connect the device to the computer through Bluetooth connection to monitor our blood oxygen saturation level is details which is keep updating in every second.

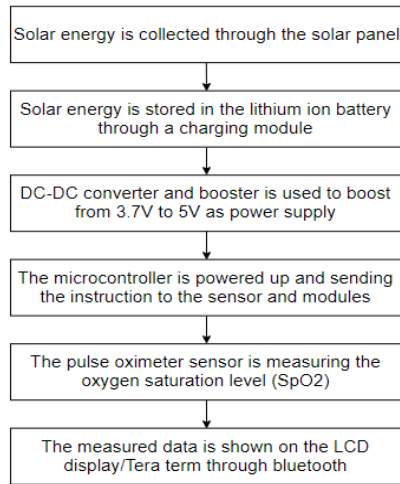

Fig. 4. Algorithm of Device.

D. Implementation Facts

The circuit diagram of the proposed solar-powered pulse oximeter monitoring with the remote alert is shown in Fig. 5. The circuit diagram consists of 16 × 2 LCD, microcontroller Atmega328, voltage regulator, oximeter sensor, potentiometer, and switch component. The circuit diagram is constructed by using Eagle software. First, the circuit or device power source voltage VCC is 5 Volt is applied. The microcontroller is powered up with 5 Volt voltage from power source. Besides that, the oximeter sensor, LCD and voltage regulator are connected in parallel from power source. After the microcontroller is starts to operate and it initiates the oximeter sensor. The oximeter has SDA and SCL as inputs to the microcontroller. The output of the microcontroller pin 4, 5, 6 and 11 are connected to the input D4, D5, D6 and D7 of the LCD display. The LCD display pin 3 used to add potentiometer for adjusting the contrast of the back light. Moreover, the pin 18 and 17 from microcontroller is connected to the LCD pin 4(register select) and pin 6(enabled).

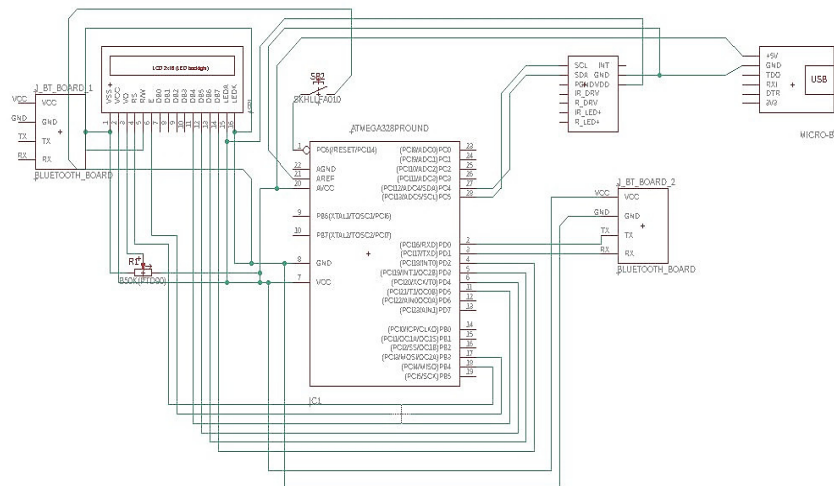

Fig. 5. Schematic Diagram of Device.

V. RESULT AND ANALYSIS

We have observed the rate of charging of the solar panel by placing it at indoor and outdoor. When the device is placed indoor, the ambient light is captured by the solar panel and the lithium battery is charged in a normal rate and is shown in the Figs. 6 and 7 respectively. The lithium ion battery is fully charged in one hour. When the device is placed outdoor, the device is exposed to the direct sunlight and the lithium ion battery is charged in a faster rate. The lithium ion battery is fully charged in.



Fig. 7. Outdoor (Direct Sunlight).



Fig. 6. Indoor Ambient Light.



Fig. 8. Result Displayed in LCD.

Fig. 8 shown above is the reading of the pulse oximeter sensor. The SpO₂ reading is shown on the LCD display which is the ratio of the red and infrared value measured through the pulse oximeter sensor. The IR value stand for the light reflection of the near-infrared (IR) light. The pulse oximeters discharge two frequency of light, red at 660nm and close IR at 940nm from a couple of light-transmitting diodes on the unit. The light is transmitted through the finger is then recognized by a photodiode on the contrary arm of the test. At the point when an individual places the fingertip on the oximeter, the light is transmitted through the finger is then identified by a photodiode. The relative amount of red and IR light absorbed to determine the hemoglobin bound to oxygen. The collected data from the sensor is then shown on the LCD display for monitoring purpose.

Fig. 9 shown is the output result on the Tera Term. The result is measured by the pulse oximeter and is transferred by Bluetooth module to the computer for data logging purpose. The reading of the pulse oximeter is keep looping until the patient lift up the finger. The values shown are the value of infrared light-IR, red light-Red, ratio of IR and Red-R and also the SpO₂. The patient can measure the blood oxygen level and sync the data with the computer through Bluetooth module. Hence, the patient can keep the data logging and send it to the doctor manually through email.

File	Edit	Setup	Control	Window	Help
IR=10920.00	Red= 2725.00	R= 0.22472832	SP02=99.39		
IR=10977.00	Red= 2766.00	R= 0.24954211	SP02=99.61		
IR=11042.00	Red= 2679.00	R= 0.25198140	SP02=99.63		
IR=10978.00	Red= 2626.00	R= 0.24261908	SP02=99.56		
IR=10908.00	Red= 2677.00	R= 0.23920569	SP02=99.53		
IR=10847.00	Red= 2737.00	R= 0.24541621	SP02=99.58		
IR=10817.00	Red= 2708.00	R= 0.25232782	SP02=99.64		
IR=10774.00	Red= 2631.00	R= 0.25034668	SP02=99.62		
IR=10717.00	Red= 2555.00	R= 0.24419898	SP02=99.57		
IR=10594.00	Red= 2520.00	R= 0.23840627	SP02=99.52		
IR=10572.00	Red= 2478.00	R= 0.23787050	SP02=99.52		
IR=10793.00	Red= 2409.00	R= 0.23439273	SP02=99.48		

Fig. 9. Reading Shown on the Terminal.

VI. CONCLUSIONS

A Solar Powered Pulse Oximeter with Remote Monitoring Network was designed in this project work. The main objective was to implement a non-conventional method of harnessing energy to power up a medical based device and to maintain the sustainability of the device. The pulse oximeter used in this project was a (MAX30102) model which is the most efficient model to work with in terms of coding and wiring. According to the results and analysis recorded based on the data collected, the end product works accordingly and the desired output is achieved. The product was finalized to cater for the user in terms of user-friendliness and also ease of access. The data collected is displayed on the LCD and more details information is shown on the computer through the Tera Term. This device helps monitor the conditions of patients in terms of blood oxygen level which is very beneficial and serves as a stepping stone to detecting health issues at an early stage. In order to achieve the portability design goals, the open source EAGLE software was used to design the circuit and miniaturize the board to make it as small as possible. A perf board was used as it allows flexibility in terms of fabrication. The components were successfully integrated into the circuit and a fully functional eco-friendly healthcare device was designed

and developed for in-house patients who lack mobility to update doctors on their condition. The future scope of this project will be modified this device such that wrist watch level compact scheme with compact level cells.

Conflict of Interest. The authors declared no conflict of interest.

REFERENCES

- [1]. Armand, M. & Tarascon, J. M. (2008). Building better batteries. *Nature*, 451, 652–657
- [2]. Roselli, L., Carvalho, N. B., Alimenti, F., Mezzanotte, P., Orecchini, G., Virili, M., & Pinho, P. (2014). Smart surfaces: Large area electronics systems for Internet of Things enabled by energy harvesting. *Proceedings of the IEEE*, 102(11), 1723-1746.
- [3]. Kim, S., Vyas, R., Bito, J., Niotaki, K., Collado, A., Georgiadis, A., & Tentzeris, M. M. (2014). Ambient RF energy-harvesting technologies for self-sustainable standalone wireless sensor platforms. *Proceedings of the IEEE*, 102(11), 1649-1666.
- [4]. Ostfeld, A. E., Gaikwad, A. M., Khan, Y., & Arias, A. C. (2016). High-performance flexible energy storage and harvesting system for wearable electronics. *Scientific reports*, 6, 26122.
- [5]. Honna, M. B. (2012). Remote Patient Monitoring System Using Pulse Oximeter. *International Journal of Scientific & Engineering Research*, 3(12), 1-4.
- [6]. Mahgoub, M. T. A., Khalifa, O. O., Sidek, K. A., & Khan, S. (2015). Health monitoring system using Pulse Oximeter with remote alert. In *2015 International Conference on Computing, Control, Networking, Electronics and Embedded Systems Engineering (ICCNEEE)*, 357-361.
- [7]. Gavhale, C. G., Karhale, P. G., Patil, K. B., Jadhav, P. K., & Pankar, M. R. (2017). Pulse Oximeter Using Arduino. *for International Journal of Research in Advent Technology (IJRAT) in "CONVERGENCE"*, 169-172.
- [8]. Azizulkarim, A. H., Jamil, M. M. A., & Ambar, R. (2017). Design and Development of Patient Monitoring System. In *IOP Conference Series: Materials Science and Engineering*, 1-7.
- [9]. Patil, H. B., & Umale, V. M. (2015). Arduino Based Wireless Biomedical Parameter Monitoring System Using Zigbee". *International Journal of Engineering Trends and Technology (IJETT)*.
- [10]. Fezari, M., Rasras, R., & El Emary, I. M. (2015). Ambulatory health monitoring system using wireless sensors node. *Procedia Computer Science*, 65, 86-94.
- [11]. Coté, C. J., Rolf, N., Liu, L. M., Goudsouzian, N. G., Ryan, J. F., Zaslavsky, A., & Alifimoff, J. K. (1991). A single-blind study of combined pulse oximetry and capnography in children. *Anesthesiology: The Journal of the American Society of Anesthesiologists*, 74(6), 980-987.
- [12]. Longmore, S. K., Lui, G. Y., Naik, G., Breen, P. P., Jalaludin, B., & Gargiulo, G. D. (2019). A comparison of reflective photoplethysmography for detection of heart rate, blood oxygen saturation, and respiration rate at various anatomical locations. *Sensors*, 19(8), 1-19.
- [13]. Sarvaiya, L., Yadav, H., & Agrawal, C. (2019). A Literature review of Diagnosis of Heart Disease using Data Mining Techniques. *International Journal of Electrical, Electronics and Computer Engineering*, 8(1), 40-45.

How to cite this article: Deivasigamani S., Narmadha, G., Ramasamy, M., Harrindradas and Nair, P. (2020). Design of Smart Pulse Oximeter using ATMEGA 328 Microcontroller. *International Journal on Emerging Technologies*, 11(3): 696–700.